

DOXA METERING PUMPS

**OFFICINE
MECCANICHE
GALLARATESI**

Sp.A.

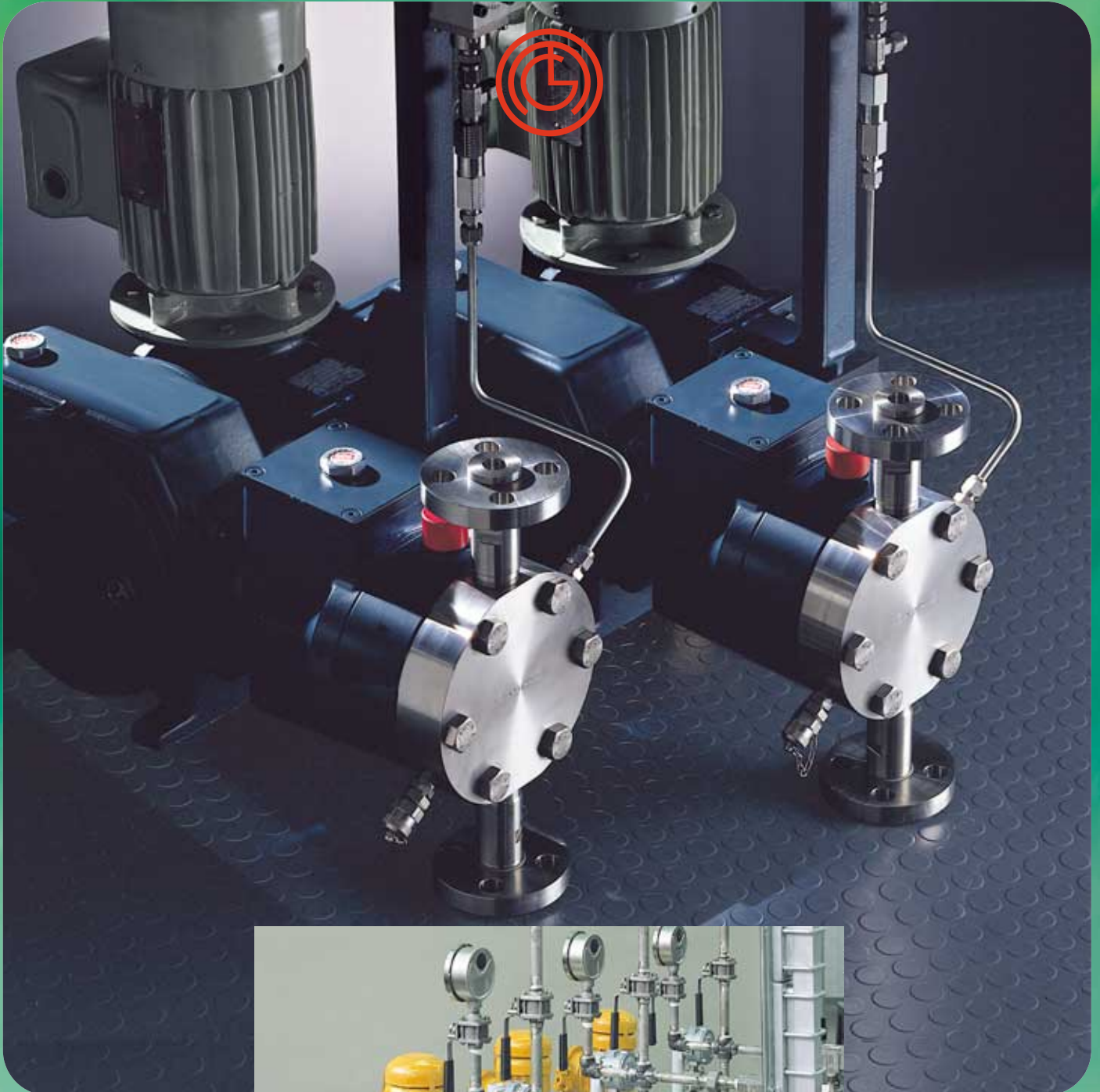

B10i
rev. 2
15.11.2000



DOXA metering pumps

- these process plunger and diaphragm metering pumps having separate hydraulic control line, have been designed to assure the greatest possible reliability in heavy duty work.
- these robust, precise, quiet running pumps having an original, patented adjustment system, are distinguished by simplicity of constructions and ease of maintenance.

specifications

- continuous adjustment of plunger stroke length, i.e. of capacity from 0 to 100% while the pump is at rest or running
- plunger stroke length adjustable from 0 to 25 mm, or also from 0 to 12 mm for low capacity diaphragm pumps
- plunger speed from 25 up to 140 strokes/min.
- metering accuracy better than 1% within the normal operating range of 10÷100% of capacity
- maximum liquid temperature for continuous operation:
 - 250° C with metal pump heads
 - 150° C with PTFE diaphragms
 - 80° C÷100° C with ceramic plunger
 - 50° C with PVC or 70° C with polypropylene pump heads
- NSPH required, less than 0.3 kg/cm² abs. at normal operating conditions, for plunger pumps
- groupable in multiplex units, also with pumps of different series
- manufactured according to API 675 Std; "non lost motion" construction; CE marked according to CEE rule 89/392

crank mechanism

- patented, single and double circular type, with mechanical plunger return stroke
- crankcase made of cast iron and completely enclosed, with oil splash lubrication, split in two sections to permit easy access
- two series available:
 - DOXA.L**, max. allowable thrust: 2000 N (design 2500 N)
 - DOXA.M**, max. allowable thrust: 7000 N (design 9000 N)

plunger pumping heads

- pump body made of metal or plastic materials
- plunger made of metal or ceramic
- standard flanged suction and discharge connections; threaded and sanitary connections upon request
- standard heads up to 40x25 with double ball-check valves; either single or double valves for models 50x25, 65x25 and 80x25; single valves only, due to the dimensions, for models 100x25 and 125x25; valve seats easily accessible and replaceable
- stuffing box with lantern ring for flushing or greasing; standard packing rings with V section or square section, made of PTFE, neoprene or impregnated fibers
- heating jacket or cooling jacket as optional; special execution with integral heating jacket for high heating efficiency.

diaphragm pumping heads

- diaphragms operated through hydraulic circuit with feed and relief valves
- metal or plastic pump body, with heating or cooling jacket on request
- elastomeric, PTFE or metal diaphragms, always double to avoid leakage due to single diaphragm rupture
- alarm device, as optional, for diaphragms rupture
- standard execution with double valves for models up to 40 DS, single or double valves on request for models 50 DS, 65 DS and 80 DS; 100 DS and 125 DS have single valves only in consideration of size; also cone valves available for higher capacity models
- special feature with remote head for dangerous, contaminated or very high temperature liquids
- three types of diaphragm pumping heads are available:

type DD with double diaphragm, for DOXA.M series only, with intermediate oil-filled chamber, mainly used for medium-high capacity

type DS with double diaphragm sandwich type, i.e. with an oil film or, for particular cases, vacuum between the diaphragms

type MM with metallic double diaphragm, sandwich type, mainly used for small capacity and high pressure or temperature.



driving motors - speed reducers

- three phase, four poles, flanged type electric motors, B5 or V1 shape, are normally supplied with dimensions according to IEC - UNEL standards; base assembled motors or bare shaft pumps, without gear reducer, are available
- speed reducer directly, or through flexible coupling, fitted to the crankcase of the first pump and oil splash lubricated
- normal crankshaft speed: 25, 35, 45, 55, 70, 87, 110, 140 r.p.m.; the direction of rotation is counterclockwise looking from the drive end

capacity control systems

- manual control, with pump at rest or in operation, by handwheel with lock knob; linear adjustment scale with precision vernier
- automatic control by means of a pneumatic positioner, either from linear or non linear signal, normal range 3÷15 psi, with emergency manual overdrive
- automatic control with positioner controlled by an electrically actuated monophasic servomotor, complete with a response potentiometer; manual stroke emergency adjustment
- speed adjustment by means of variable speed motor, with manual or automatic adjustment
- electric pulses generator and pulsemeter to meter a fixed liquid quantity

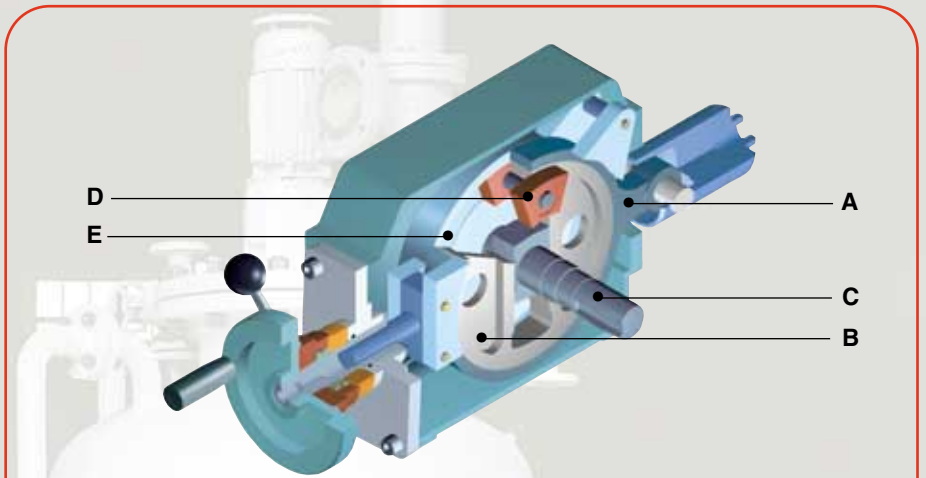

structural arrangement of the crank mechanism

- the connecting-rod (A) is driven by the pump's shaft (C) by means of a bushing (B) to which a slide (D) is attached which travels along the circular guide (E) with every revolution of the shaft and hence of the bushing
- the motion of the connecting rod results from the rotation of the slide in the circular guide and of the bushing with the shaft, whose rectangular section allows the bushing to slide
- the plunger stroke can be regulated by varying the eccentricity of the circular guide
- it is worthwhile to note that two double plunger strokes correspond to each revolution of the shaft and that, for higher performances, two slides, instead of one, travelling in circular guides on opposing sides of the connecting rod are provided, in order to get better equilibrated thrusts
- this metering system is patented

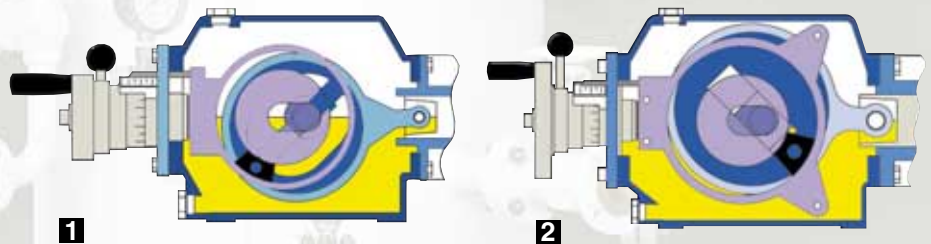

1

2

1. sectional view of DOXA.L crank mechanism
2. sectional view of DOXA.M crank mechanism
3. package unit with DOXA.M diaphragm pumps
4. handwheel for manual stroke adjustment
5. DOXA.L plunger pumps on skid



3



4



5



tab. A1 plunger pumps ratings and technical data

model plunger dia. x stroke	plunger area	volume		maximum capacity		max. admissible back pressure continuous service (2)		max. discharge pressure (bar), with motor rated kW:					flanges (4)		
		cm ²	cm ³ stroke	strokes min	liters hr	liters hr	DOXA.L	DOXA.M	0,37 kW (3)	0,55 kW	0,75 kW	1,1 kW	1,5 kW	UNI DN	ANSI nom. size
5x25	0,196	0,491	70	2,06	1,8	200	500	200	500	—	—	—	10	1/2"	
			87	2,56	2,2										
			110	3,24	2,9										
7x25	0,385	0,962	70	4,04	3,7	200	500	170	500	—	—	—	10	1/2"	
			87	5,02	4,6										
			110	6,35	5,8										
10x25	0,785	1,963	70	8,2	7,7	200	500	150	400	500	—	—	10	1/2"	
			87	10,2	9,6										
			110	12,9	12										
15x25	1,767	4,418	70	18,5	17	115	400	60	200	280	400	—	10	1/2"	
			87	23	22										
			110	29,1	27										
20x25	3,142	7,854	70	33	31	65	230	30	110	150	230	—	15	1/2"	
			87	41	39										
			110	51,8	50										
25x25	4,909	12,27	70	51,5	49	40	150	20	75	100	150	—	15	1/2"	
			87	64	61										
			110	81	77										
30x25	7,069	17,67	70	74	70	30	100	15	50	70	100	—	15	1/2"	
			87	92	87										
			110	116	110										
40x25	12,56	31,41	70	132	125	16	60	—	28	40	60	—	20	3/4"	
			87	164	156										
			110	207	197										
50x25	19,63	49,08	70	206	196	10	40	—	18	24	40	—	20	3/4"	
			87	256	243										
			110	324	310										
65x25	33,18	82,95	70	348	330	6	22	—	10	15	22	—	25	1"	
			87	433	410										
			110	547	520										
80x25	50,26	125,60	70	527	500	4	15	—	7	9	15	—	25	1"	
			87	655	620										
			110	829	800										
100x25	78,54	196,30	70	824	780	—	10	—	4	6	9	10	40	1 1/2"	
			87	1025	975										
			110	1295	1230										
125x25	122,70	306,70	70	1288	1220	—	6	—	3	4	6	—	40	1 1/2"	
			87	1600	1520										
			110	2025	1925										

- (1) the volumetric efficiency can vary from 90% to 99%, according to pump work pressure, liquid handled, r.p.m., etc.
 (2) for the horse power of these single acting pumps, the maximum discharge pressure must be considered and not the maximum differential pressure
 (3) motor power 0.37 kW for DOXA.L pumps only
 (4) the flanges are normally supplied in accordance with UNI 2223-67 PN 40 or ANSI B 16.5 unless higher pressure is required; upon request, flanges in accordance with other standards can be supplied.

tab. B1 standard material for plunger pumps

part	execution	316	PVC	HC
body		AISI 316	PVC	Hastelloy-C 276
plunger		AISI 316 or ceramic	ceramic or Hastelloy-C 276	ceramic or Hastelloy-C 276
ball valves		AISI 316 or AISI 420	pyrex or ceramic	Hastelloy-C 276 or ceramic
valve seats		AISI 316	PVC	Hastelloy-C 276
packing		PTFE impregnated fibres or neoprene	PTFE	PTFE

pumping heads

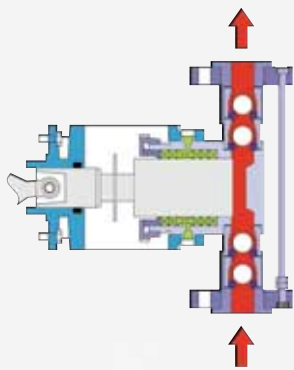

1

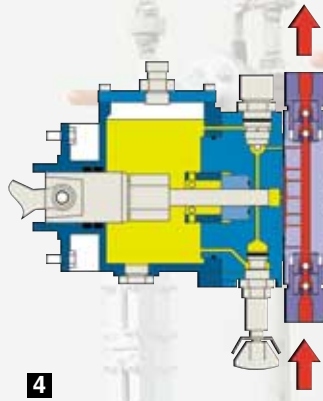

4

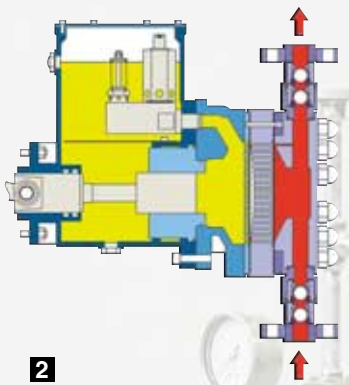

2

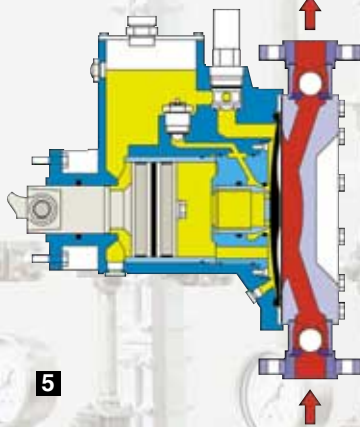

5

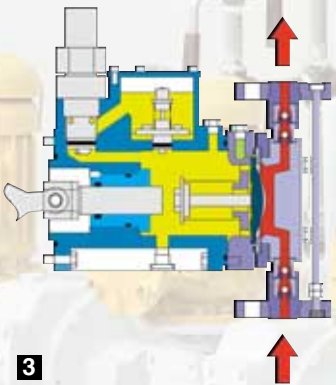

3

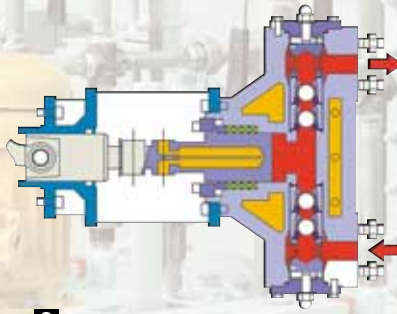

6

- 1. DOXA pump: plunger head
- 2. DOXA.M pump: double diaphragm head DD type
- 3. DOXA.L pump: double diaphragm head DS type
- 4. DOXA.L pump: double diaphragm head MM type
- 5. DOXA.M pump: double diaphragm head DS type with horizontal parallel flanges
- 6. DOXA.M pump: plunger head with integral heating jacket
- 7. DOXA.M pump: double diaphragm head DS type with vertical flanges

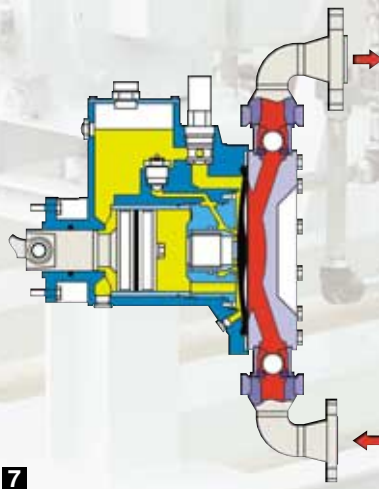

7









tab. A2 diaphragm pumps ratings and technical data

model: piston dia. x stroke (1)	piston area	volume		maximum capacity		max. admissible back pressure continuous service (3)			max. discharge pressure (bar), with motors rated kW:					flanges (5)										
																theoretical	actual (2)	DOXA.L		DOXA.M			UNI DN	ANSI
																		DS	MM	DD, DS, MM				
																mm	cm ²	cm ³ stroke	strokes min	liters hr	liters hr	bar	bar	bar
7x25	0,385	0,962	70	4,04	3,6	65	200	100	170	200	—	—	—	10	1/2"									
			87	5,02	4,5				160	200	—	—	—											
			110	6,35	5,7				150	200	—	—	—											
10x25	0,785	1,963	70	8,2	7,4	65	200	100	150	200	—	—	—	10	1/2"									
			87	10,2	9,2				140	200	—	—	—											
			110	12,9	11,7				130	200	—	—	—											
15x25	1,767	4,418	70	18,5	16,5	65	120	100	60	120	—	—	—	10	1/2"									
			87	23	20				58	120	—	—	—											
			110	29,1	26				55	120	—	—	—											
20x25	3,142	7,854	70	33	29	65	—	100	30	100	—	—	—	15	1/2"									
			87	41	36				28	80	100	—	—											
			110	51,8	45				25	65	95	100	—			—								
25x25	4,909	12,27	70	51,5	45	40	—	100	20	70	95	100	—	15	1/2"									
			87	64	57				18	55	75	100	—											
			110	81	72				16	45	60	90	100			—								
30x25	7,069	17,67	70	74	66	30	—	100	15	45	65	95	100	20	3/4"									
			87	92	83				14	35	55	80	100											
			110	116	105				13	30	40	60	90			—								
40x25	12,56	31,41	70	132	118	16	—	60	—	25	35	55	60	20	3/4"									
			87	164	145				—	20	30	43	60											
			110	207	185				—	16	24	35	50			—								
50x25	19,63	49,08	70	206	180	10	—	40	—	18	24	35	40	20	3/4"									
			87	256	230				—	15	20	30	40											
			110	324	290				—	10	15	22	32			—								
65x25	33,18	82,95	70	348	310	6	—	22	—	9	15	20	22	25	1"									
			87	433	380				—	8	11	17	22											
			110	547	500				—	6	9	13	19			—								
80x25	50,26	125,6	70	527	470	4	—	15	—	6	9	14	15	25	1"									
			87	655	600				—	5	7,5	11	15											
			110	829	750				—	4	6	9	12			—								
100x25	78,54	196,3	70	824	740	—	—	10	—	(4)	6	7	10	40	1 1/2"									
			87	1025	920				—	(3,5)	5	5,5	10											
			110	1295	1160				—	(2,5)	3,5	5,5	8			—								
125x25	122,7	306,7	70	1288	1150	—	—	6	—	(2,5)	4	5,5	6	40	1 1/2"									
			87	1600	1400				—	(2)	3	4,5	6											
			110	2025	1850				—	(1,5)	2,5	3,5	5			—								

- (1) piston stroke can be 12.5 mm with capacity half of the one given for 25 mm stroke
(2) with volumetric efficiency 90%; efficiency decreases by about 1%, every 7-8 bar increase of discharge pressure
(3) for horse power of these single acting pumps, the maximum discharge pressure must be considered and not the maximum differential pressure
(4) motor power 0.37 kW for DOXA.L pumps only
(5) the flanges are normally supplied in accordance with UNI 2223-67 PN 40 or ANSI B 16.5, unless higher pressure is required;
upon request, flanges in accordance with other standards can be supplied.

tab. B2 standard construction materials for diaphragm pumps

part	execution	316	PVC	HC
body		AISI 316	PVC	Hastelloy-C 276
diaphragms		PTFE or AISI 316	PTFE	PTFE or Hastelloy-C 276
ball valves		AISI 316 or AISI 420	pyrex or ceramic	Hastelloy-C 276 or ceramic
valve seats		AISI 316	PVC	Hastelloy-C 276

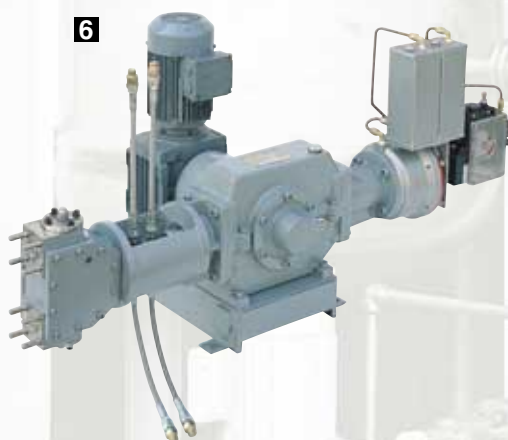

1. DOXA.L pump - DD type

2. duplex DOXA.L pump - DS type with electric actuator

3. DOXA.L pump - DS type, with pneumatic positioner

4. DOXA.M pump - plunger type with electric actuator

5. DOXA.L pump - MM type

6. DOXA.M pump - plunger type with integral heating jacket

7. DOXA.L pump - MM type

8. DOXA.L pump - MM type with remote head

overall dimensions of DOXA pumps

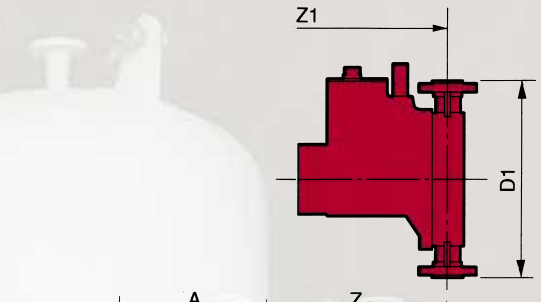
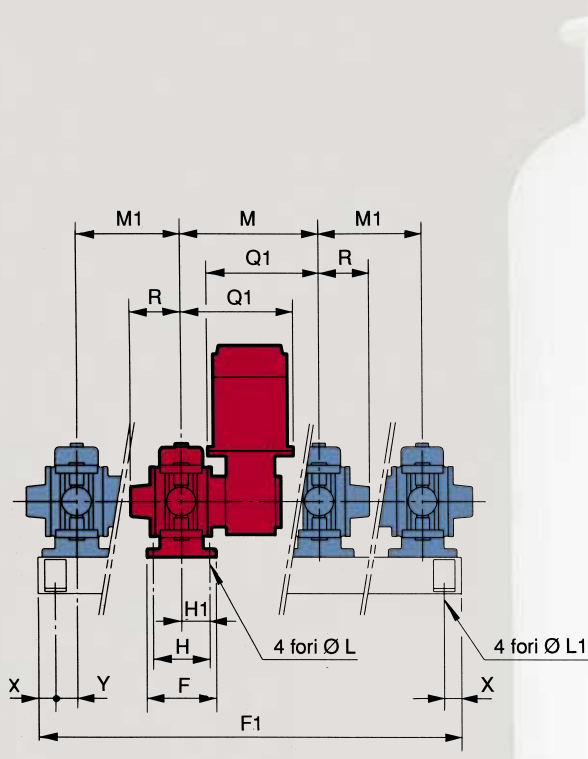

1

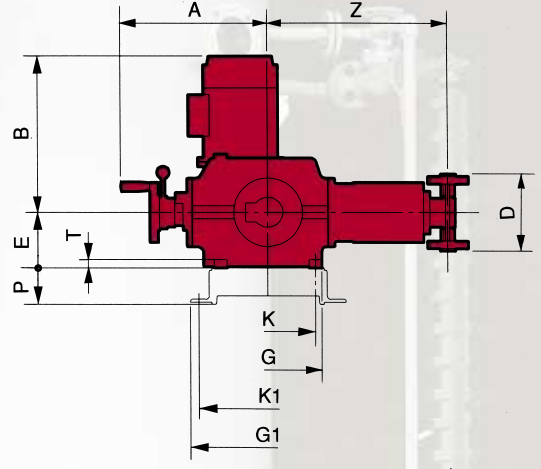

2

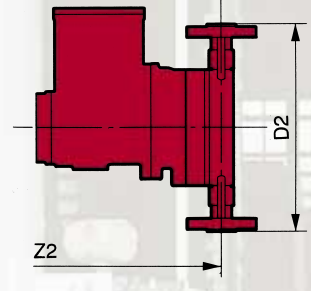

3

- 1. double diaphragm head DS and MM type
- 2. manual adjustment plunger head
- 3. diaphragm head DD type
- 4. automatic pneumatic characterizable adjustment
- 5. automatic pneumatic linear adjustment
- 6. automatic electric adjustment

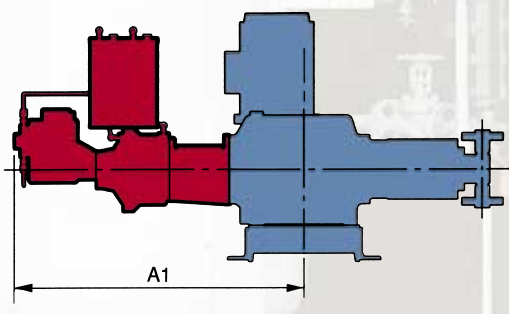

4

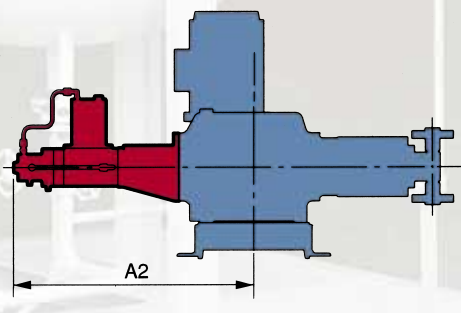

5

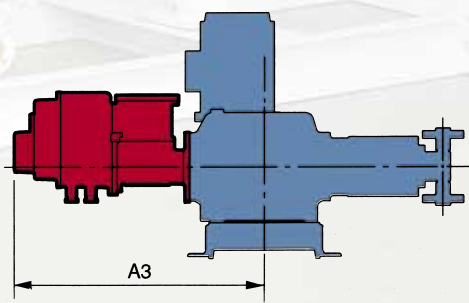

6



overall dimensions of DOXA pumps (mm)

pump model

DOXA.L	A	A1	A2	A3	E	F	G	G1	H	H1	K	K1	L	L1	M	M1	P	R	T	X	Y
plunger	315	625	535	560	110	155	210	220	125	53	180	170	11	15	328	165	75	125	12	25	135
diaphragm	315	625	535	560	110	155	210	220	125	53	180	170	11	15	328	250(*)	75	(**)	12	25	135
DOXA.M	A	A1	A2	A3	E	F	G	G1	H	H1	K	K1	L	L1	M	M1	P	R	T	X	Y
plunger	340	685	—	585	130	160	250	360	130	65	220	320	11	18	320÷379	240	85	125	20	40	50
diaphragm	340	685	—	585	130	160	250	360	130	65	220	320	11	18	320÷379	400(*)	85	(**)	20	40	50

(*) M1 can change for different liquid ends

(**) see below diaphragm pumps tab.

model	DOXA.L plunger pumps					DOXA.M plunger pumps				
	dimension D				dimension Z	dimension D				dimension Z
	single valves		double valves			single valves		double valves		
	inox	PVC	inox	PVC		inox	PVC	inox	PVC	
5x25, 7x25, 10x25, 15x25	—	—	162	146	337	—	—	162	146	417
20x25, 25x25, 30x25	—	—	180	162	337	—	—	178	160	417
40x25	—	—	222	206	337	—	—	222	206	432
50x25	180	164	234	218	337	233	217	233	217	432
65x25	211	195	281	265	337	280	264	280	264	432
80x25	232	216	302	286	337	305	289	305	289	455
100x25, 125x25	—	—	—	—	—	305	368	—	—	455

model	DOXA.L diaphragm pumps									DOXA.M diaphragm pumps											
	dimension D1, R, Z1									dimensions D1, D2, R, Z1, Z2											
	sandwich type MM			sandwich type DS						sandwich type DS			sandwich type MM			type DD with intermed. chamber					
	D1	R	Z1	D1	R	Z1	D1	R	Z1	D1	R	Z1	D1	R	Z1	D2	R	Z2	D2	R	Z2
7 x 12	276	125	337	235	125	335	223	125	335	—	—	—	—	—	—	—	—	—	—	—	—
7x25, 10x25, 15x12	318	125	337	235	125	335	223	125	335	—	—	—	—	—	—	—	—	—	—	—	—
15 x 25	363	125	352	235	125	335	223	125	335	—	—	—	—	—	—	—	—	—	—	—	—
20 x 25	—	—	—	235	125	335	223	125	335	—	—	—	515	160	478	278	125	535	304	125	550
25 x 25	—	—	—	261	125	343	249	125	343	—	—	—	515	160	478	326	140	535	370	140	550
30 x 25	—	—	—	261	125	343	249	125	343	340	125	421	544	160	478	340	140	535	372	140	550
40 x 25	—	—	—	314	125	387	302	125	387	340	125	421	544	160	478	354	140	535	374	140	550
50 x 25	—	—	—	346	125	387	334	125	387	340	125	421	544	160	478	385	140	535	405	140	550
65 x 25	—	—	—	346	125	387	334	125	387	411	125	426	641	190	505	474	170	565	494	170	580
80 x 25	—	—	—	—	—	—	—	—	—	411	125	426	641	190	505	473	170	575	508	170	590
100 x 25, 125 x 25	—	—	—	—	—	—	—	—	—	450	160	485	—	—	—	558	190	580	632	190	590

n° of heads	dimension F1 for DOXA.L pumps				dimension F1 for DOXA.M pumps			
	plunger with gear:		diaphragm with gear:		plunger with gear:		diaphragm with gear:	
	at side	in the middle	at side	in the middle	at side	in the middle	at side	in the middle
2	470	640	580	640	495	495 ÷ 670	670	495 ÷ 670
3	640	820	760	905	735	735 ÷ 910	975	910 ÷ 975
4	820	970	1105	1105	975	975 ÷ 1070	1390	1390
5	970	1135	1255	1315	1215	1215 ÷ 1390	1870	1870
6	1135	1315	1465	1585	1470	1470 ÷ 1630	2270	2270

kW motor	DOXA.L pumps		DOXA.M pumps	
	B	Q1	B	Q1
0,37	310 ÷ 360	235 ÷ 253	—	—
0,55 - 0,75	330 ÷ 390	255 ÷ 273	330 ÷ 430	260 ÷ 290
1,1 - 1,5	—	—	350 ÷ 490	260 ÷ 290

Officine Meccaniche Gallaratesi,
established in 1907,
has been manufacturing positive
displacement pumps for more
than 80 years.

The company is highly specialized
in design and production of
reciprocating plunger and
diaphragm metering pumps as
well as complete package units
including O.M.G. pumps.
In its field of activity, O.M.G. has
always given priority to reliable
solutions, in order to be able to
satisfy the most demanding
requirements of advanced
industrial users and engineering
companies.

The result of this choice is that
today O.M.G. can be ranked
among the most well known and
technologically advanced
companies in the market.



OFFICINE MECCANICHE GALLARATESI Sp.A.

sales office

Via C. Tenca, 1 • 20124 Milano • Italy
ph. +39-02-66984910 • fax +39-02-6705462

factory & administration

Via Cinque Giornate, 5 • 21013 Gallarate (VA) • Italy
ph. +39-0331-750011 • fax +39-0331-777035

e-mail: omgpumps@omgpumps.com
www.omgpumps.com

agents

France • United Kingdom • Moldova • Poland • Romania • Spain • Ukraine
Turkey • Egypt • South Africa • Sudan • China • Korea • Taiwan
Saudi Arabia • United Arab Emirates • Jordan • Iran • Israel • Iraq
Kuwait • Bahrain • Pakistan • Qatar • Syria • New Zealand